

OWNER'S MANUAL

LATERAL RAISE

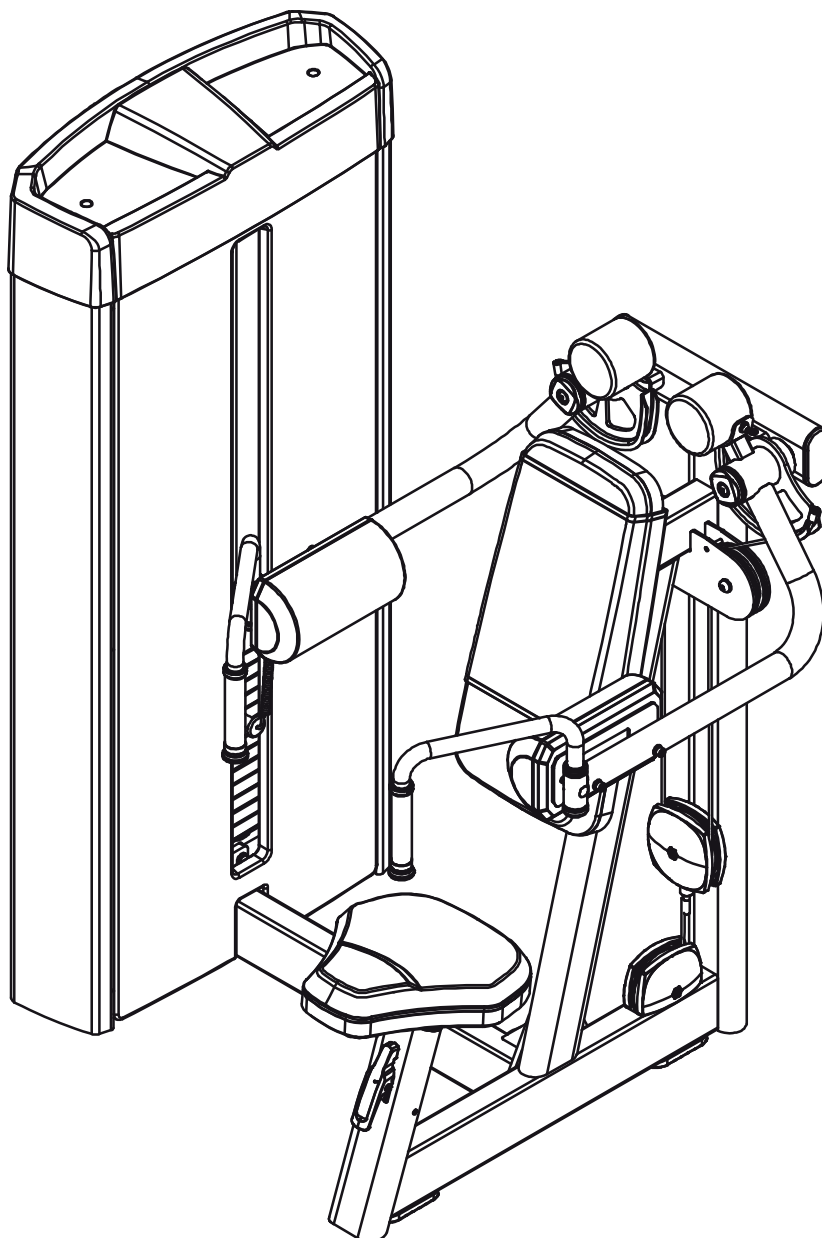

CAUTION

Please read all instructions in this manual before use the equipment and keep the manual well.

Cautions

In order to avoid human injuries and property damages, before the use of this series equipment, please read the following important notices.

1. Before use of the equipment please read this Owner's Manual carefully. The equipment should be assembled and used strictly following the relevant instructions in this manual, and can not change any of its components or disassemble it freely.
2. It should be ensured that all users have been fully aware of the safety warnings and precautions before they exercise on the equipment.
3. Too loose-fitting clothing can not be worn, and sports shoes should be put on while exercising.
4. The equipment should be carefully examined before training. If there is damage, please do not use it and do not try to repair it by yourself. Please contact your supplier in time. It is necessary to inform after-sales service personnel as soon as possible to get the machine repaired.
5. Make sure the selector pin has fit well in its position before exercising and do not use selector pin other than the one coupled with this equipment to avoid any injury.(Apply to single station with cable)
6. The equipment should be placed indoors, and make sure that the ground is flat, and there are enough space around the equipment for user to exercise on the machine freely.
7. Before using the machine, please check the cables to ensure that cable is in the groove of pulley, and attention should be paid especially to the end of cable. (Apply to single station with cable)
8. Only originally attached or manufacturer provided weight stack can be used in this

equipment and can not increase the weight of weight stack by use of other manufacturers, weight stack plate. (Apply to single station with cable)

9. Child and pet are not allowed to be too close to the equipment while it is in using.
10. If exerciser feels dizzy or physical pain while training he or she should stop exercising immediately and consult a doctor.
11. The equipment should be used in a well defined place and under well managed and monitored way of the equipment owner.

Before using the equipment please consult your physician and fitness expert, and must be sure to read all the specifications in this owner's manual. Manufacturer will not be held responsible for any personal injury and property loss resulted from the incorrect use of the products.

Equipment Schematic

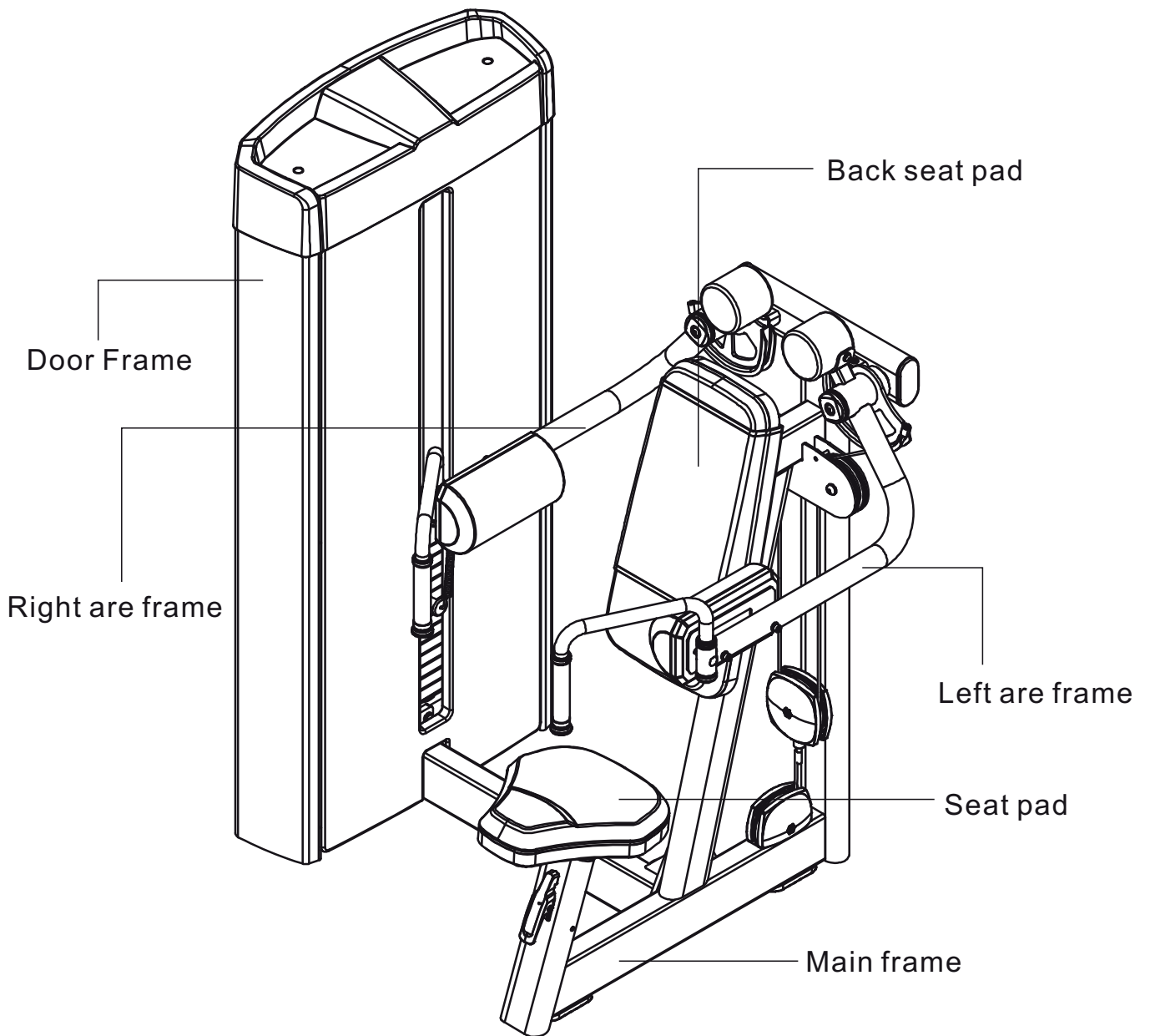

Fitting instructions

1. When strip off the wrappage around the surface of equipment, should be careful, do not hurt the machine with knife scratches on the surface.
2. When moving this equipment, a sufficient number of personnel should be used to prevent the equipment from collision, or to avoid the injuries caused by personnel shortage.
3. Prior to installation of the equipment, make sure that all the parts are complete, no missing hardware.
4. When install the equipment, should have two or more persons working together to ensure the accurate location of parts assembly.
5. When install the equipment should pay attention to the assembly instructions to prevent component fitting to a wrong place or some components being omitted.
6. The suitable installation tools should be used to avoid the equipment damages or human injuries caused by the use of inappropriate tools in the installation process.
7. If need to move equipment, the movement must be after the completion of installation. The equipment can not be moved when the installation process hasn't finished or locking nut hasn't been tightened up.
8. Attention should be paid to the sequence of fastening locking nut, when the overall installation of the equipment is not finished, should not tighten up the nut that is being installed. After the whole machine is properly fitted together, the locking nuts can be tightened up one by one.
9. Before installation the cable terminals should be checked to make sure whether they are firm. (Apply to single station with cable)
10. After the completion of installation, start the initial trial of the equipment with gentle

force. Make certain that the equipment is without any abnormality before normally use the machine. If something unusual is found with the equipment that, it is necessary to check the equipment carefully, identify the problems and reinstall it.

Warranty

*Ten years: Main Frames

*One year: Bushings, Pivot bearings, guide rods, Weight plate, cams, swivel welding parts, Pull-pin components

*Half year: Finish, rubber grips, belt, cables.

*Three Months: upholstery

Assembly step 1

Step	No.	Description	Specifications	Qty
1	1	Door Frame		1
	20	Inner Hexagon Socket Head Bolt	M10*35	4
	24	Spring washer	M10	4
	27	Flat washer	Φ20*Φ10.5*2	4
	53	Pulley set		1
	72	Half pulley cover		2
	75	Ring		2
	76	End cover		2
	86	Hexagon socket screw on umbrella head	M10*25	2
	92	Hexagon socket screws with cylindrical head	M10*50	1
	93	Hexagon socket screws with cylindrical head	M10*35	3
	95	Flat washer	φ20*φ10.5*2	4
	98	Spring washer	M10	5
	99	Nut	M10	2

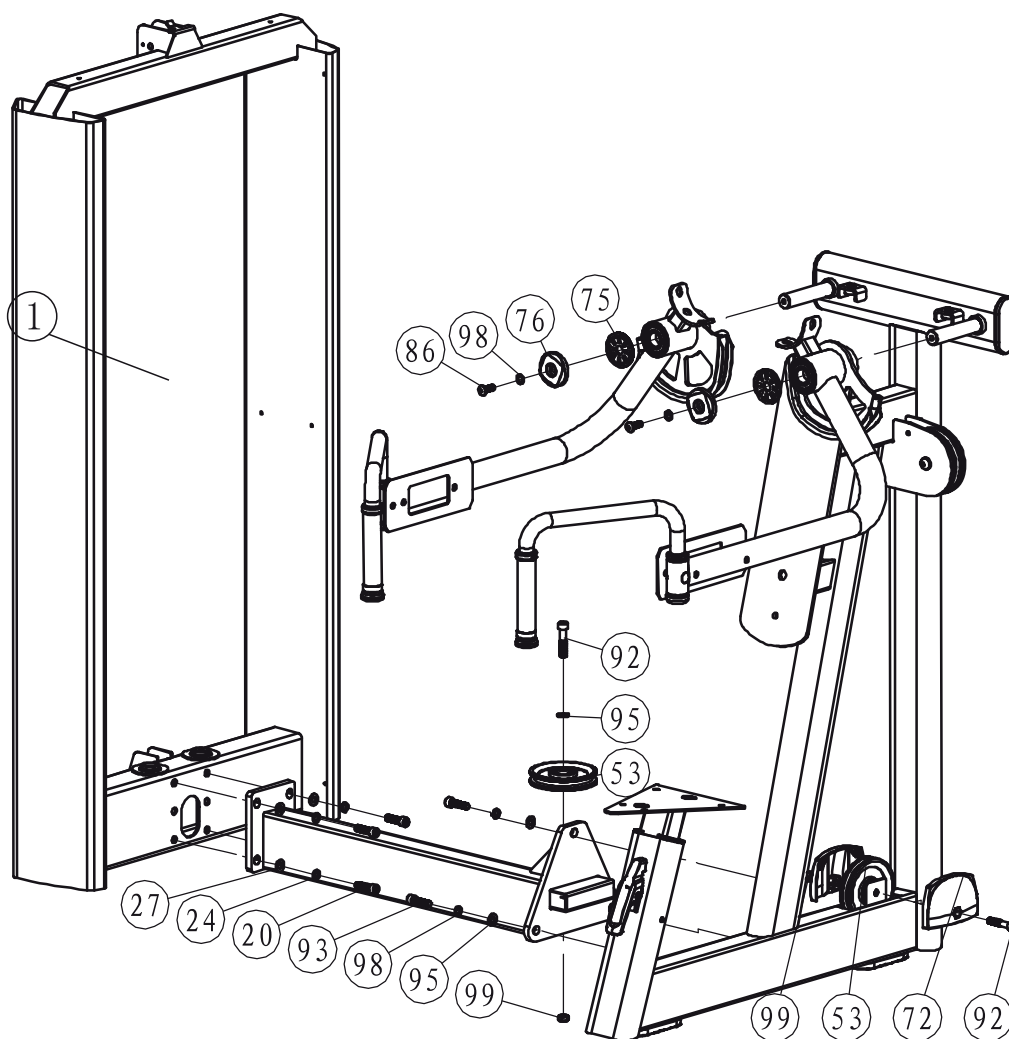

Assembly step 2

Step	No.	Description	Specifications	Qty
2	65	Half round cushion		2
	79	Seat pad		1
	80	Back seat pad		1
	88	Hexagon socket screw on umbrella head	M8*30	2
	90	Hexagon socket screws with cylindrical head	M8*30	5
	91	Hexagon socket screws with cylindrical head	M8*85	4
	94	Flat washer	$\Phi 16*\Phi 8.4*1.6$	12
	97	Spring washer	M8	12

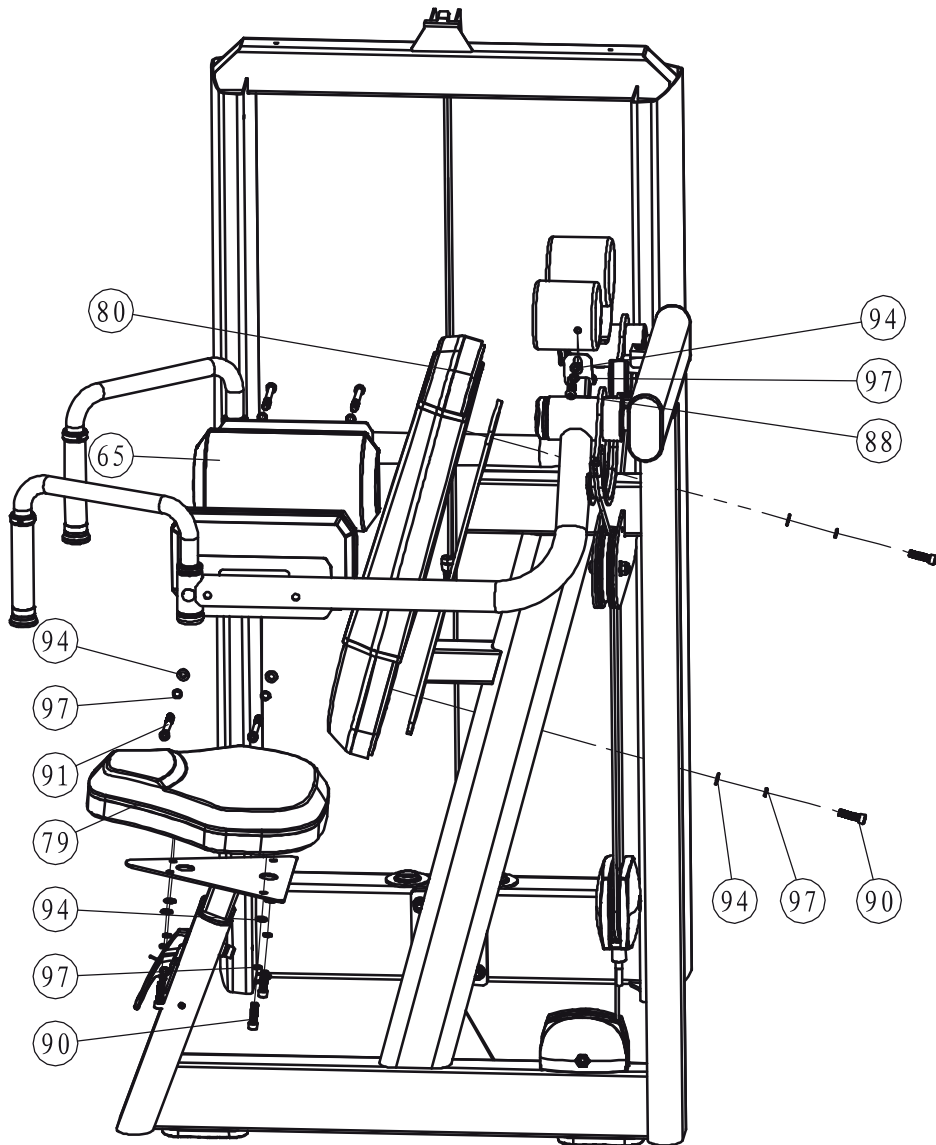

Assembly step 3

Step	No.	Description	Specifications	Qty
3	4	Guide rod		2
	5	Guide rod fixed plate		1
	9	Rubber bumper	$\phi 64 * \phi 32 * \phi 20 * 35$	2
	10	Rubber bumper	$\phi 38 * \phi 21 * 10$	2
	12	Rod end cover		4
	13	Pulley sets	$\phi 89 * 32$	2
	14	Selector pin		1
	19	Inner Hexagon Socket Head Bolt	M8*20	2
	21	Inner Hexagon Socket Head Bolt	M10*55	2
	23	Spring washer	M8	2
	26	Flat washer	$\Phi 16 * \Phi 8.4 * 1.6$	2
	27	Flat washer	$\Phi 20 * \Phi 10.5 * 2$	4
	28	Nylon nut	M10	2
	57	10 pounds of optional iron components		14
	58	10pounds counterweight components		1

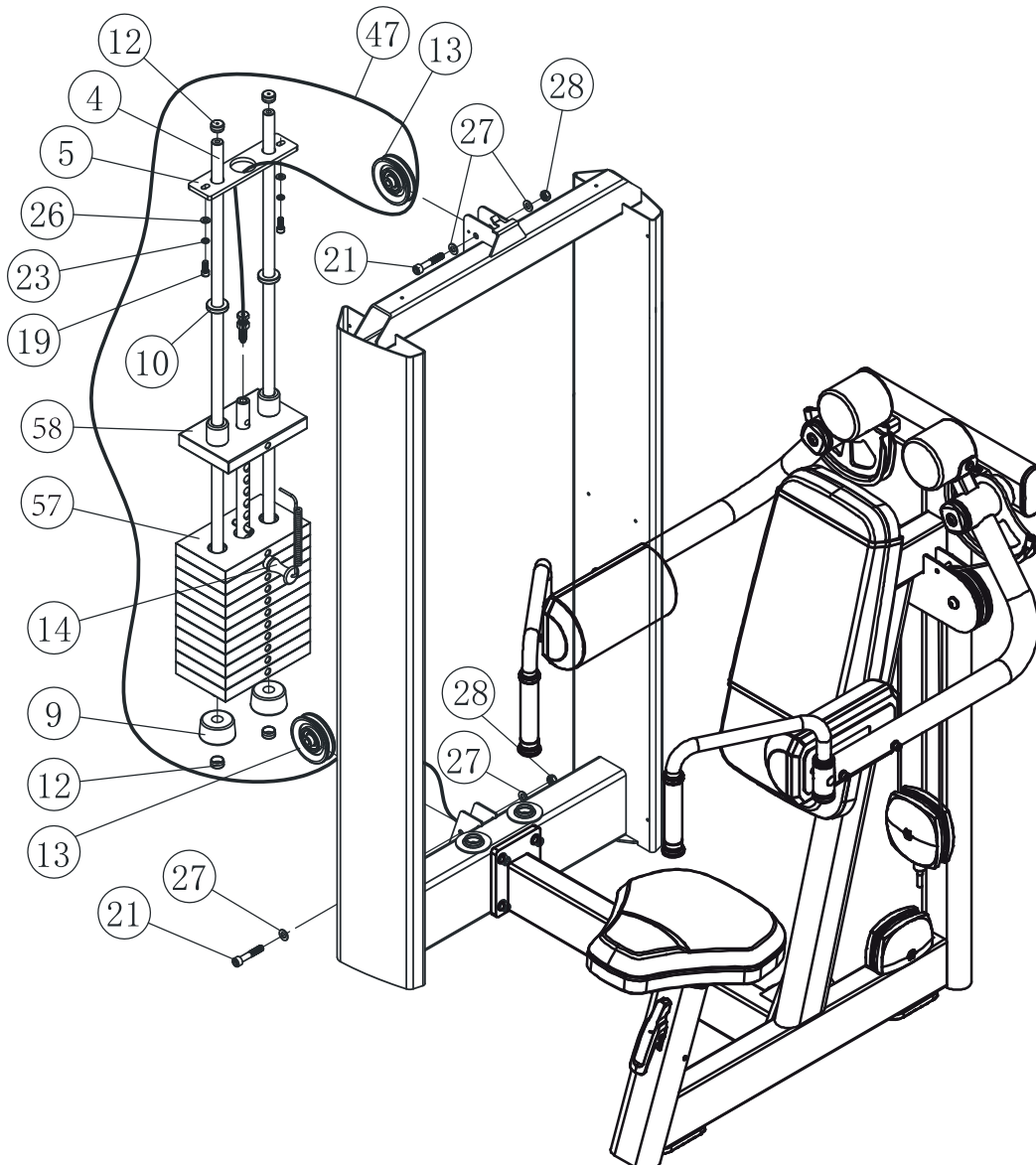

Assembly step 4

Step	No.	Description	Specifications	Qty
4	2	Upper shield		1
	3	Shield fixed plate		4
	6	Fixed bushing		12
	7	Front shield		1
	8	Back shield		1
	15	cross recessed countersunk head screw	M5*10	8
	16	Countersunk head hexagon socket screw	M6*16	12
	18	Inner Hexagon Socket Head Bolt	M6*16	2
	22	Spring washer	M6	2
	25	Flat washer	$\Phi 12 * \Phi 6.4 * 1.6$	2

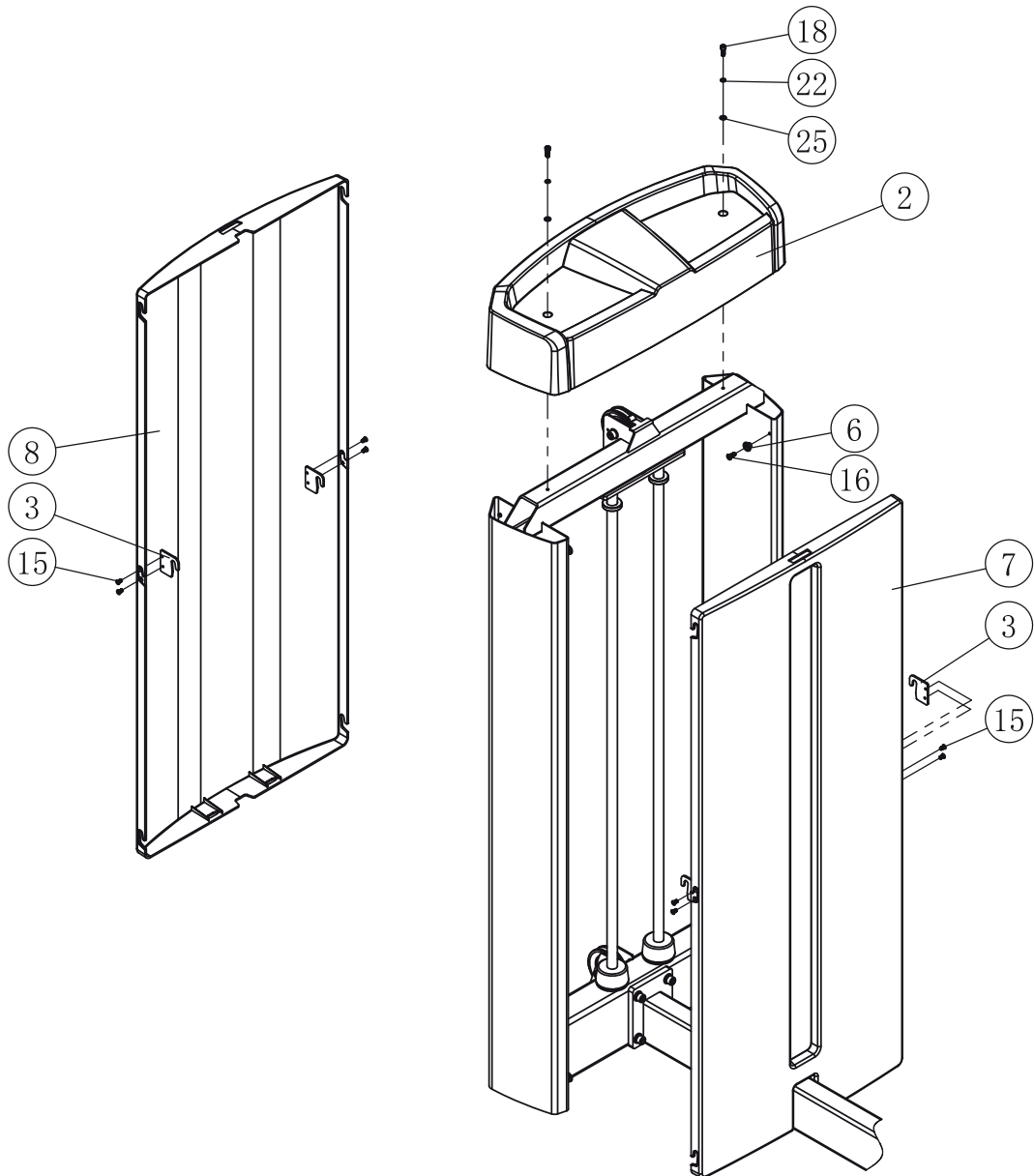

CABLE ROUTING DIAGRAM

Correct

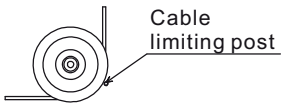

Wrong

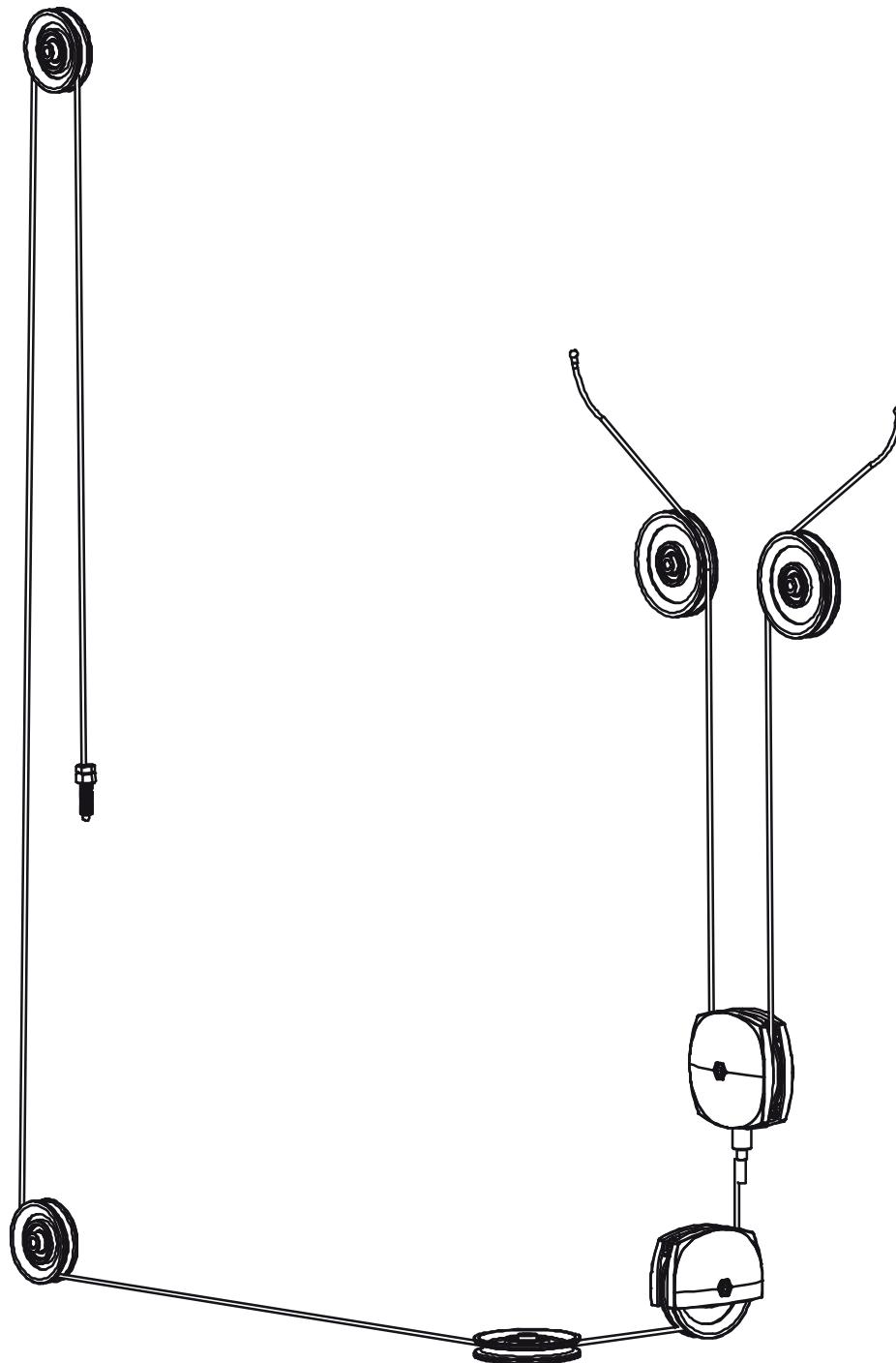
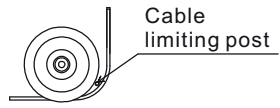

Exploded View

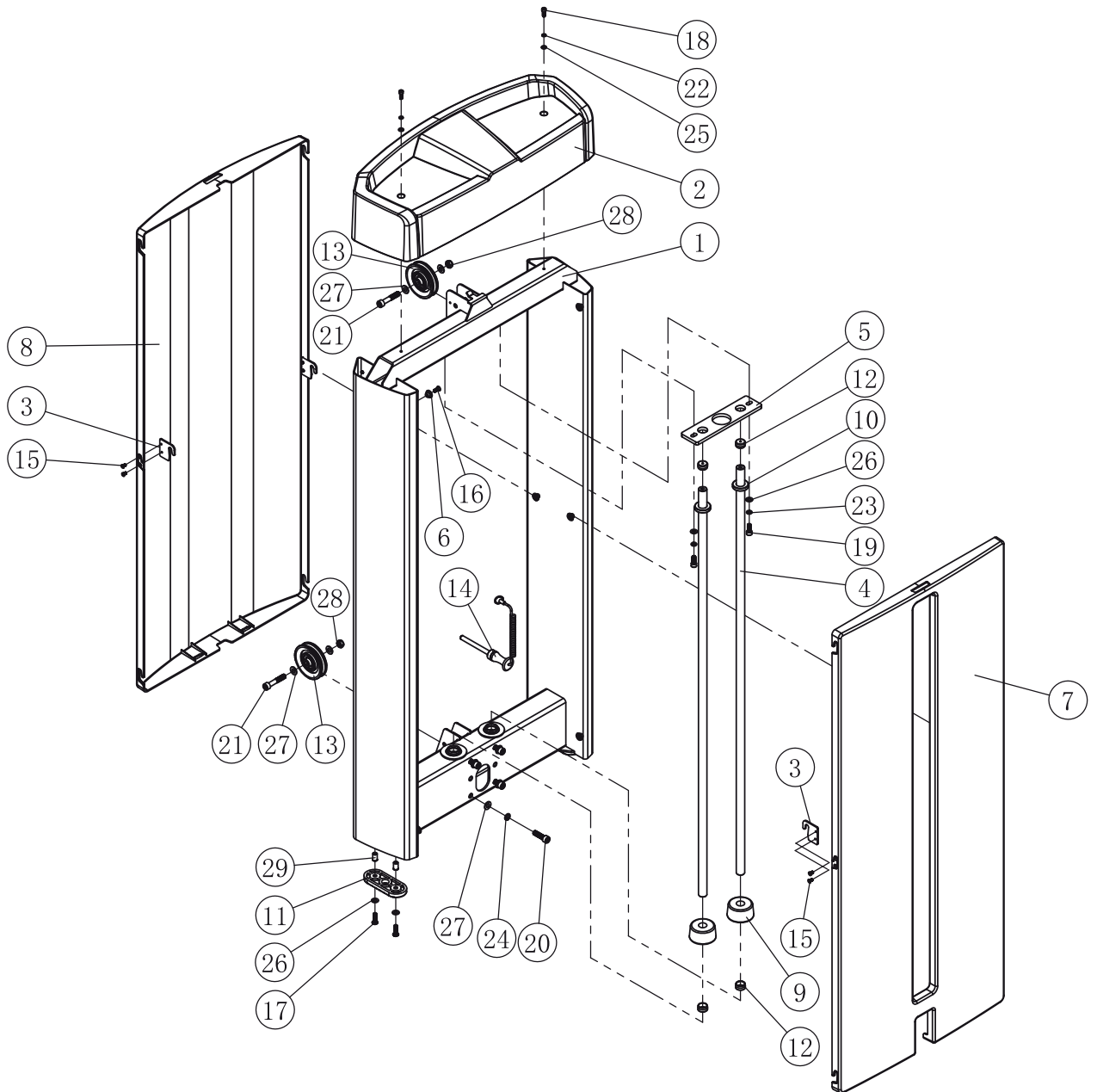

Exploded List

No.	Description	Specifications	Qty
1	Doorframe		1
2	Upper shield		1
3	Shield fixed plate		4
4	Guide rod		2
5	Guide rod fixed plate		1
6	Fixed bushing		12
7	Front shield		1
8	Back shield		1
9	Rubber bumper	$\phi 64 * \phi 32 * \phi 20 * 35$	2
10	Rubber bumper	$\phi 38 * \phi 21 * 10$	2
11	Floor cushion		2
12	Rod end cover		4
13	Pulley sets	$\phi 89 * 32$	2
14	Selector pin		1
15	cross recessed countersunk head screw	M5*10	8
16	Countersunk head hexagon socket screw	M6*16	12
17	Inner Hexagon Mushroom Head Bolt	M8*25	4
18	Inner Hexagon Socket Head Bolt	M6*16	2
19	Inner Hexagon Socket Head Bolt	M8*20	2
20	Inner Hexagon Socket Head Bolt	M10*35	4
21	Inner Hexagon Socket Head Bolt	M10*55	2
22	Spring washer	M6	2
23	Spring washer	M8	2
24	Spring washer	M10	4
25	Flat washer	$\Phi 12 * \Phi 6.4 * 1.6$	2
26	Flat washer	$\Phi 16 * \Phi 8.4 * 1.6$	6
27	Flat washer	$\Phi 20 * \Phi 10.5 * 2$	8
28	Nylon nut	M10	2
29	Rivet nut with small countersunk head	M8*18	4
30			
31			
32			
33			
34			
35			
36			
37			
38			
39			
40			
41			
42			

Exploded View

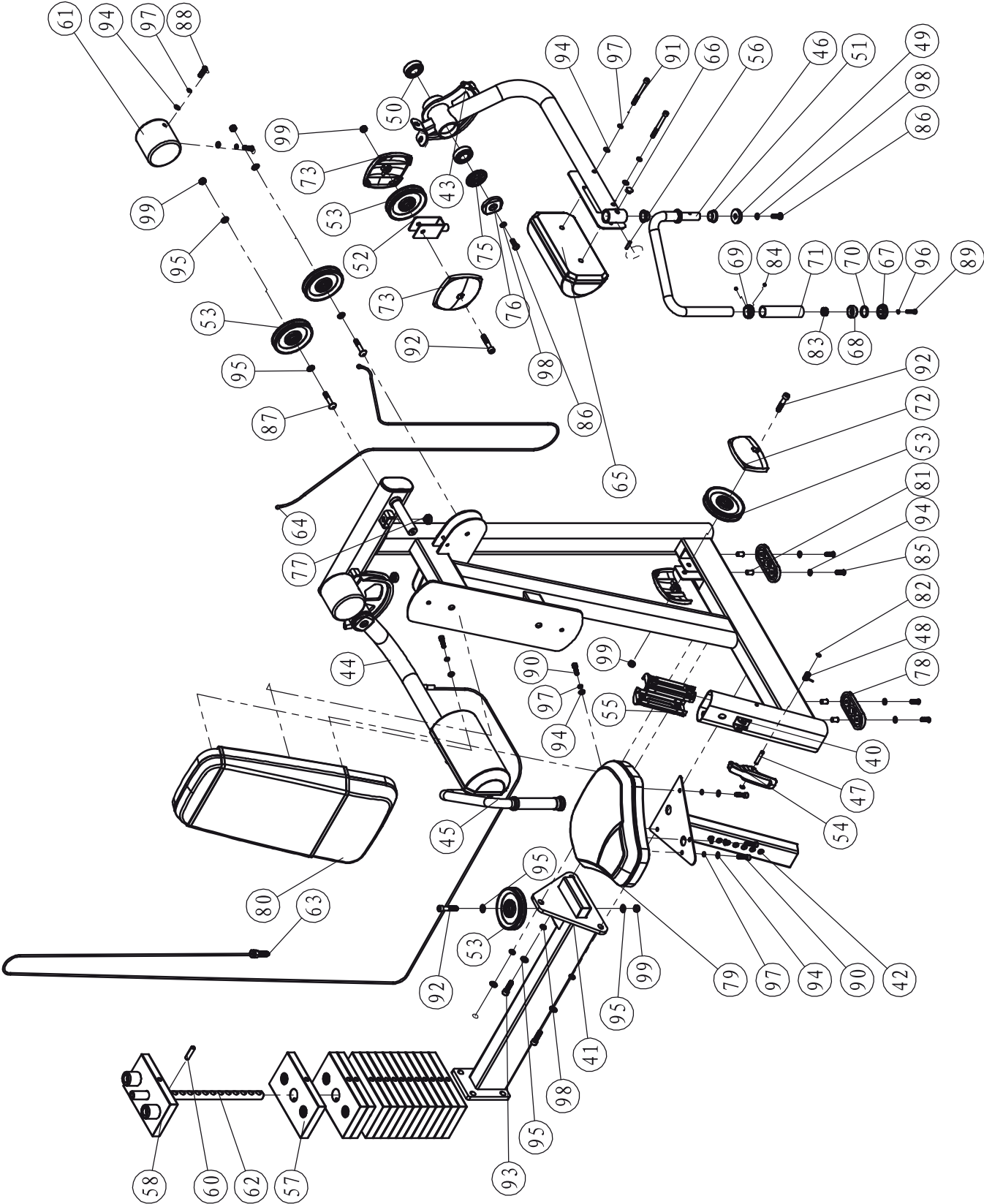

Exploded List

No.	Description	Specifications	Qty
40	Main frame		1
41	Connection frame		1
42	Cushion adjusting rack		1
43	Left are frame		1
44	Right are frame		1
45	Right handle frame		1
46	Left handle frame		1
47	Fixed axis		1
48	Torsion spring		1
49	End cover		2
50	Step rolling bearing		4
51	Metallurgy set		4
52	Lifting pulley bracket		1
53	Pulley set		5
54	Adjusting handle		1
55	Sliding sleeve set		2
56	Elastic cylindrical pin	6*25	2
57	10 pounds of optional iron components		14
58	10pounds counterweight components		1
59	Limit screw		1
60	Elastic cylindrical pin	10*45	1
61	Balance iron		2
62	15 hole selection shaft		1
63	Cable set 1		1
64	Cable set 2		1
65	Half round cushion		2
66	Plug		2
67	Aluminum plug		2
68	Aluminum ring		2
69	Aluminum baffle ring		2
70	Plastic ring		2
71	Gloves handles with through-hole		2
72	Half pulley cover		2
73	Pulley cover		2
74	Elliptical pipe plug		2
75	Ring		2
76	End cover		2
77	Cushion		2
78	Bottom mat		2
79	Seat pad		1
80	Back seat pad		1
81	Small countersunk head rivet nut	M8*18	4

Exploded List

No.	Description	Specifications	Qty
82	Open ring	d=6	2
83	Reed nut	M6*Φ20.8*10	2
84	Set screws with inner hexagonal cone end	M5*5	4
85	Hexagon socket screw on umbrella head	M8*25	4
86	Hexagon socket screw on umbrella head	M10*25	4
87	Hexagon socket screw on umbrella head	M10*50	2
88	Hexagon socket screw on umbrella head	M8*30	4
89	Hexagon socket screws with cylindrical head	M6*25	2
90	Hexagon socket screws with cylindrical head	M8*30	6
91	Hexagon socket screws with cylindrical head	M8*85	4
92	Hexagon socket screws with cylindrical head	M10*50	3
93	Hexagon socket screws with cylindrical head	M10*35	3
94	Flat washer	Φ16*Φ8.4*1.6	18
95	Flat washer	φ20*φ10.5*2	9
96	Spring washer	M6	2
97	Spring washer	M8	14
98	Spring washer	M10	8
99	Nut	M10	5
100			
101			
102			
103			
104			
105			
106			
107			
108			
109			
110			
111			
112			
113			
114			
115			
116			
117			
118			
119			
120			
121			
122			
123			

Maintenance Attentions

Daily Maintenance (Basic Maintenance)

1. Clean the seat pad, back pad and cushion with warm water and soft cloth in order to avoid the sweat erosion to these component.
2. Clean the frame with warm water and soft cloth.
3. Cleaning chrome plated parts: wipe them with alcohol moistened soft cloth.

Monthly Maintenance (Basic Maintenance)

1. Check transmission cable. Check the tightness and abrasion of the cable (disrepair of the surface, bend, distortion and so on). (Apply to single station with cable)
2. Check guide rod, and wipe it with soft duster cloth and alcohol, and lubricate it by anticorrosive oil, but please don't let excessive oil accumulated on rod. (Apply to single station with cable)
3. Check weight stack to know if there is any damaged steel plate which caused by too much force or friction on rod. (Apply to single station with cable)
4. Check pulley on whether its groove surface is clean and whether it runs smoothly. (Apply to single station with cable)
5. Check bolts and fixing parts. Wipe them with alcohol and anticorrosive oil.

Further Maintenance

1. Check whether bolts on basic frame become loose, springs have damaged and the tightness of drive cable.
2. Check, if there is rust or paint loss on main frame and basic rack, clean out rust by sand paper, and then cover it with same color paint from the same supplier.
3. Clean and lubricate every bearing, and keep equipment work smoothly.
4. Check whether the oil cylinder suffers oil leakage.

Weight stack label instructions

1. Wipe front surface of weight stack .
2. Peel off back sheet (adhesive side) from label and make sure that the label remains attached to the application tape.
3. Aline the center hole of label with the weight stack center hole.
4. Line up the first label to hole on top plate.
5. Make sure label is straight and slowly press into place.
6. Gently remove application tape and rub each label firmly against the weight stack.
7. Allow labels to stand for 24 hours to allow adhesive to cure fully.

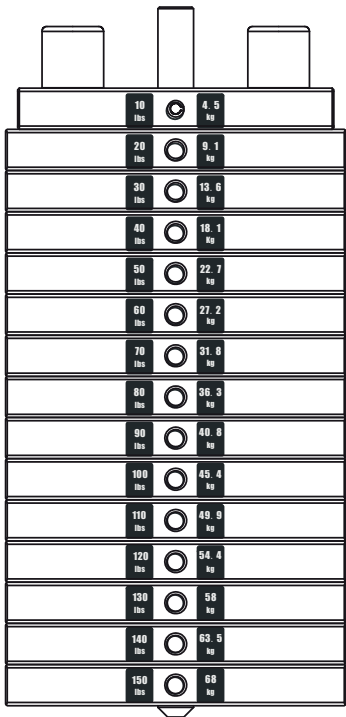

10 lbs	<input type="radio"/>	4.5 kg
20 lbs	<input type="radio"/>	9.1 kg
30 lbs	<input type="radio"/>	13.6 kg
40 lbs	<input type="radio"/>	18.1 kg
50 lbs	<input type="radio"/>	22.7 kg
60 lbs	<input type="radio"/>	27.2 kg
70 lbs	<input type="radio"/>	31.8 kg
80 lbs	<input type="radio"/>	36.3 kg
90 lbs	<input type="radio"/>	40.8 kg
100 lbs	<input type="radio"/>	45.4 kg
110 lbs	<input type="radio"/>	49.9 kg
120 lbs	<input type="radio"/>	54.4 kg
130 lbs	<input type="radio"/>	58 kg
140 lbs	<input type="radio"/>	63.5 kg
150 lbs	<input type="radio"/>	68 kg

